

3/8"

1/2"

3/4"

SLEEVE-DRIVE SOCKETS SLEEVE-DRIVE STECKSCHLÜSSEL DOUILLES, SLEEVE DRIVE



Sleeve-Drive Sockets

Sleeve-Drive Steckschlüssel

Douilles, Sleeve Drive



The deepened drive end of the **Sleeve-Drive** tools prevents the sometimes "wobbly" connection between pulse tool - extension - socket. An O-ring inside **Sleeve-Drive** optimizes the perfect fit of extension bars and sockets on the anvil to the effect, that the exactness of the required torque given by the pulse tool is generally improved. Further, the **Sleeve-Drive** avoids the direct transmission of vibrations on the pulse tool and finally on the operator.

Der **Sleeve-Drive** Vierkant-Antrieb vermeidet durch die vertiefte Passung den "Wackelkontakt" zwischen Maschine - Verlängerung - Steckschlüssel. Ein im **Antriebsende der Sleeve-Drive-Steckschlüssel** eingesetzter Ring optimiert den festen Sitz der Verlängerungen und Steckschlüssel auf der Schrauberspindel und sorgt somit für die unmittelbare Weitergabe des vorgegebenen Drehmomentes ohne wesentliche Drehkraftverluste. Nicht zuletzt vermeidet der **Sleeve-Drive** Antrieb die Übertragung von Schwingungen auf Mensch und Maschine.

Ces nouveaux outils **Sleeve-Drive** se caractérisent par un entraînement carré allongé et un joint torique incorporé. Le guidage rigide ainsi obtenu maintient les outils **Sleeve-Drive** dans l'axe de la broche de la machine et garantit une connection optimale machine-rallonges-douilles. Le jeu latéral et les vibrations engendrés par les outils traditionnels sont de ce fait supprimés. Il en résulte une transmission plus précise du coupe de serrage et un plus grand confort de travail pour l'opérateur.

Sleeve Drive Sockets

Wrenches

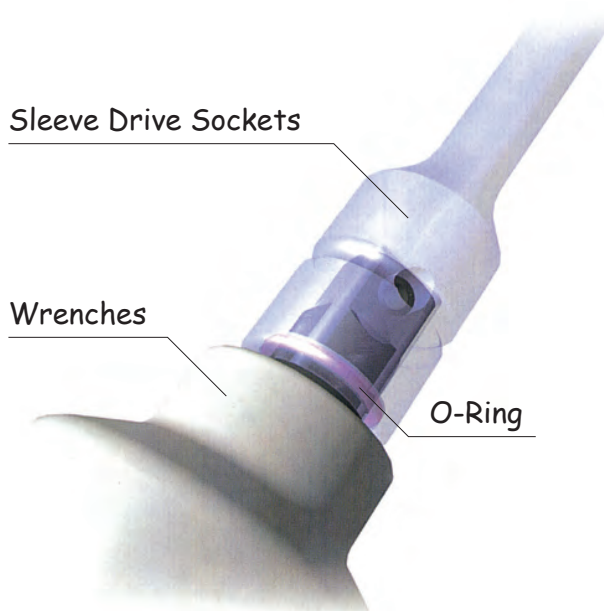

SLEEVE DRIVE SOCKET PULSE TOOL

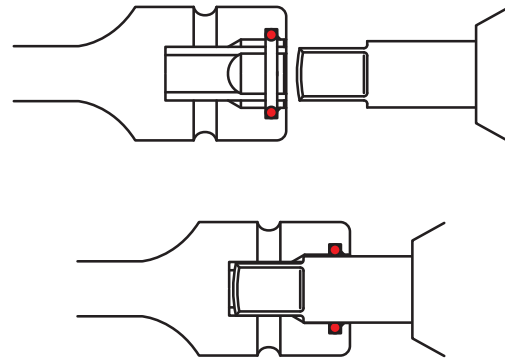

The "**Sleeve Drive**" Sockets and accessories are designed for use on Pulse Tools with anvils of certain lengths and diameters as shown hereunder.

Die serienmässigen "**Sleeve Drive**" Steckschlüssel können nur auf Impuls Schraubern mit Antriebswellen der nachstehenden Längen und Durchmesser gesteckt werden.

Les douilles "**Sleeve Drive**" ne peuvent être placées que sur des axes des boulonneuses à impulsions d'une longueur et d'un diamètre selon la spécification ci-dessous.

	Anvil Diameter (mm)	Minimum Anvil Length (mm)
3/8"sq.	12	10
1/2"sq.	16	10
3/4"sq.	25	11.8

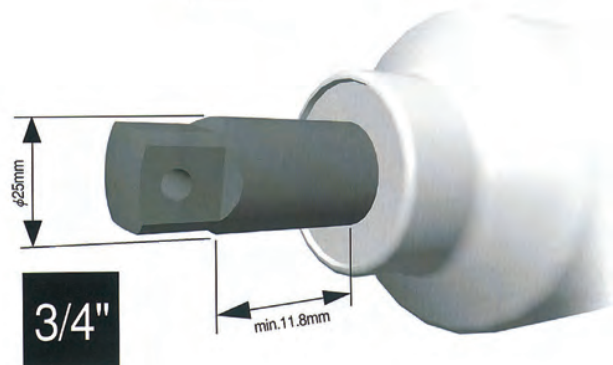
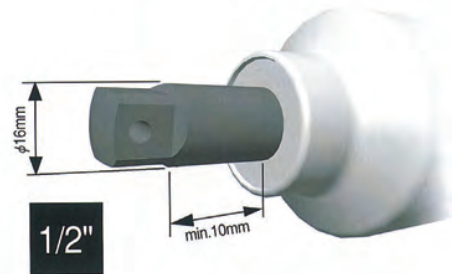
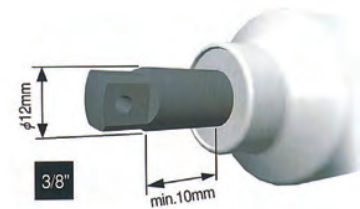

3/8" Sleeve-Drive Sockets

Sleeve-Drive Steckschlüssel

Douilles, Sleeve Drive

NV13400 (mm)	D ₁ (mm)	D ₂ (mm)	H (mm)	L (mm)	(g)	(pcs.)	Ⓢ
8	13.3	19	6	43	53	10	*1
10	15.8	19	7	43	53	10	*1
11	17	19	8	43	54	10	*1
12	18.3	19	9	43	55	10	*1
13	19.5	22	10	43	80	10	*2
14	20.8	22	10	43	80	10	*2
15	22	22	11	43	81	10	*2
16	23.3	22	11	43	83	10	*2
17	24.5	22	11	43	85	10	*2
18	25.8	22	11	43	89	10	*2
19	27	22	11	43	98	10	*2
21	29.5	22	11	43	105	10	*2
22	30.8	22	11	43	112	10	*2

*1 C-Ring=C31, Pin/O-Ring=A31/B31

*2 C-Ring=C32, Pin/O-Ring=A32/B32

➔ P268-269

NV13400

6-point Sockets
6-kant Steckschlüssel
Douilles 6-pans



NV13145-100 (mm)	D ₁ (mm)	D ₂ (mm)	H (mm)	L (mm)	(g)	(pcs.)	Ⓢ
6	13	19	6	100	108	5	*1
8	13	19	8	100	110	5	*1
10	15.5	19	10	100	112	5	*1
12	18	19	12	100	120	5	*1
13	19	19	13	100	127	5	*1
14	21	19	14	100	131	5	*1
15	22	19	15	100	133	5	*1
16	24	19	15	100	144	5	*1
17	25	19	15	100	154	5	*1

NV13145-150 (mm)	D ₁ (mm)	D ₂ (mm)	H (mm)	L (mm)	(g)	(pcs.)	Ⓢ
6	13	19	6	150	160	5	*1
8	13	19	8	150	160	5	*1
10	15.5	19	10	150	165	5	*1
12	18	19	12	150	168	5	*1
13	19	19	13	150	170	5	*1
14	21	19	14	150	175	5	*1
15	22	19	15	150	177	5	*1
16	24	19	15	150	190	5	*1
17	25	19	15	150	203	5	*1

NV13145-200 (mm)	D ₁ (mm)	D ₂ (mm)	H (mm)	L (mm)	(g)	(pcs.)	Ⓢ
6	13	19	6	200	210	5	*1
8	13	19	8	200	210	5	*1
10	15.5	19	10	200	212	5	*1
12	18	19	12	200	214	5	*1
13	19	19	13	200	218	5	*1
14	21	19	14	200	220	5	*1
15	22	19	15	200	226	5	*1
16	24	19	15	200	235	5	*1
17	25	19	15	200	250	5	*1

*1 C-Ring=C31, Pin/O-Ring=A31/B31

➔ P268-269

NV13145-100 / -150 / -200

Extended Sockets
Schaftsteckschlüssel
Douilles rallongées

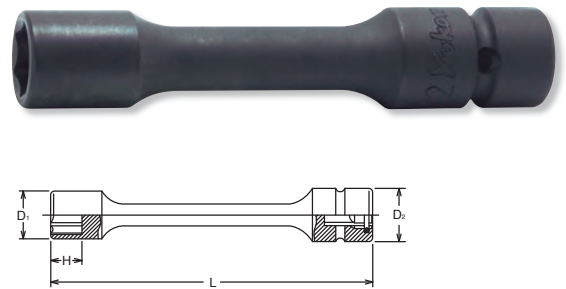

	D (mm)	L (mm)	(g)	(pcs.)	Ⓢ
NV13760-75P	19	75	95	10	*1
NV13760-125P	19	125	125	5	*1
NV13760-150P	19	150	150	5	*1
NV13760-250P	19	250	255	5	*1

*1 C-Ring=C31, Pin/O-Ring=A31/B31

➔ P268-269

NV13760-P

Extension Bars
Verlängerungen
Rallonges

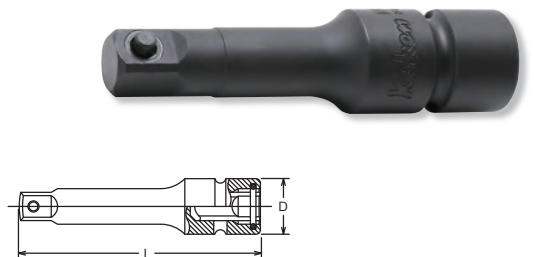

Z-SERIES
HAND
TITANIUM
ACCESSORIES
SCREWDRIVERS
IMPACT
SLEEVE-DRIVE
PROTECTOR
INDUSTRIAL
AUTOMOTIVE
MOTORCYCLE
CONSTRUCTION
SPARE PART

Sleeve-Drive Sockets

Sleeve-Drive Steckschlüssel

Douilles, Sleeve Drive

3/8", 1/2"

183H-35 / -75 / -150

Hex Bits
Sechskant Bits
Embout, 6 pans creux

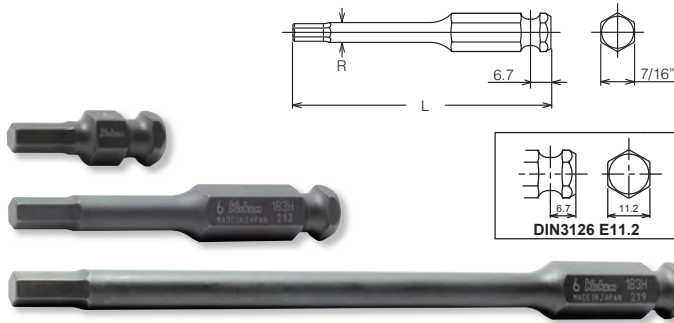

183H-35 (mm)	L (mm)	(g)	(pcs.)
3	35	15	10
4	35	15	10
5	35	15	10
6	35	18	10
7	35	19	10
8	35	20	10
9	35	23	10
10	35	26	10
11	35	28	10
12	35	30	10
14	35	35	10
16	35	47	10
17	35	50	10
18	35	53	10
19	35	56	10

183H-35 (inch)	L (mm)	(g)	(pcs.)
3/16	35	15	10
7/32	35	16	10
1/4	35	18	10
5/16	35	20	10
3/8	35	26	10
7/16	35	28	10
1/2	35	38	10

183H-75 (mm)	L (mm)	R (mm)	(g)	(pcs.)
3	75	6	34	10
4	75	6	35	10
5	75	6.5	36	10
6	75	7.5	39	10
7	75	8.5	44	10
8	75	9.5	47	10
10	75	-	57	10
11	75	-	60	10
12	75	-	65	10
14	75	-	79	10

183H-150 (mm)	L (mm)	R (mm)	(g)	(pcs.)
4	150	6	51	10
5	150	6.5	55	10
6	150	7.5	65	10
8	150	9.5	87	10
10	150	-	118	10
12	150	-	136	10

183H-75B / -150B

Ball-point Hex Bits
Sechskant Bits mit Kugelkopf
Embout hexagonal à tête sphérique

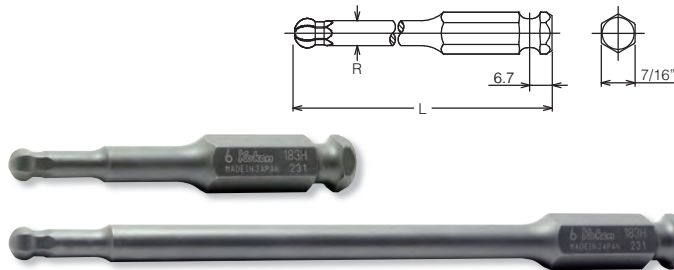

183H-75B (mm)	L (mm)	R (mm)	(g)	(pcs.)
6B	75	5.7	39	10
8B	75	7.7	44	10
10B	75	9.7	49	10
12B	75	11.7	72	10

183H-150B (mm)	L (mm)	R (mm)	(g)	(pcs.)
6B	150	5.7	65	10
8B	150	7.7	71	10
10B	150	9.7	92	10
12B	150	11.7	135	10

183T-35 / -75 / -150 (T)

TORX® Bits
TORX® Bits
Embout, TORX®

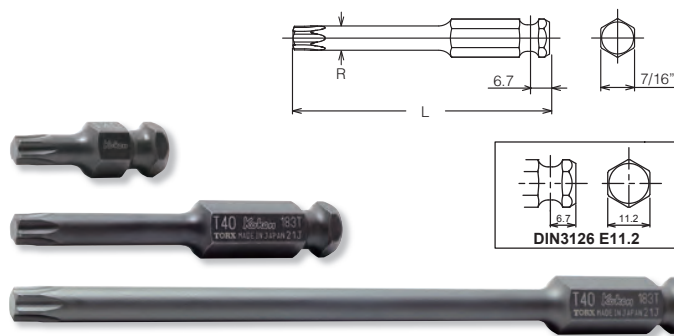

183T-35 (T)	L (mm)	(g)	(pcs.)
T25	35	18	10
T30	35	18	10
T40	35	20	10
T45	35	22	10
T50	35	26	10
T55	35	30	10
T60	35	38	10

183T-75 (T)	L (mm)	R (mm)	(g)	(pcs.)
T25	75	6	33	10
T27	75	6	33	10
T30	75	6	35	10
T40	75	6.9	37	10
T45	75	8	41	10
T50	75	9	45	10
T55	75	11.4	55	10
T60	75	13.5	67	10

183T-150 (T)	L (mm)	R (mm)	(g)	(pcs.)
T30	150	6	50	10
T40	150	6.9	58	10
T45	150	8	70	10
T50	150	9	82	10
T55	150	11.4	113	10
T60	150	13.5	148	10

The items with have larger output sizes than 7/16" Input drive.
Due to this design the maximum output torque rating is less than standard.

Die mit gekennzeichneten Artikel haben größere Abtriebsgrößen als der 7/16" Antrieb.
Aufgrund dieser Konstruktion ist das maximale Abtriebsdrehmoment geringer als der Standardwert.

Les articles marqués d'un ont des tailles de sortie plus importantes que l'entraînement d'entrée 7/16".
En raison de cette conception, le couple de sortie maximum est inférieur au couple standard.

TORX® is a registered trademark of CAMCAR Innovations.
TORX® ist ein registriertes Markenzeichen der Firma CAMCAR Innovations.
TORX® est une marque déposée de CAMCAR Innovations.

3/8", 1/2"

Sleeve-Drive Sockets
Sleeve-Drive Steckschlüssel
Douilles, Sleeve Drive

183T-35 (IP)	L (mm)	(g)	(pcs.)
30IP	35	18	10
40IP	35	20	10
45IP	35	22	10
50IP	35	26	10
55IP	35	30	10
60IP	35	38	10

183T-75 (IP)	L (mm)	R (mm)	(g)	(pcs.)
30IP	75	6	35	10
40IP	75	6.8	37	10
45IP	75	8	41	10
50IP	75	9	45	10
55IP	75	11.4	56	10
60IP	75	13.5	67	10

183T-35 / -75 (IP)

TORXPLUS® Bits
TORXPLUS® Bits
Emboutis TORXPLUS®

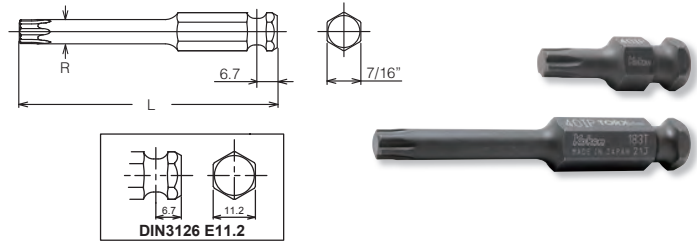

183X-35 / -75 / -150 (XZN)

XZN Bits
XZN Bits
Emboutis, XZN

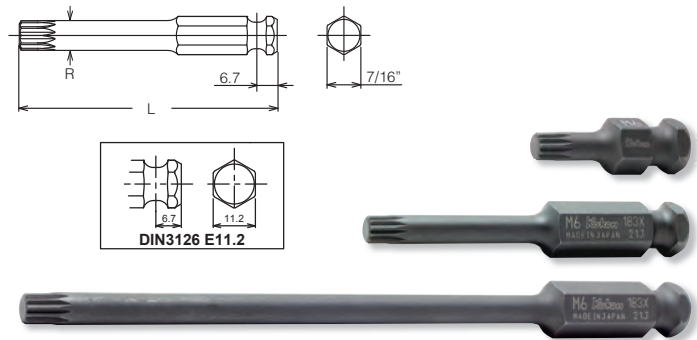

183X-35 (XZN)	L (mm)	(g)	(pcs.)
M 4	35	18	10
M 5	35	18	10
M 6	35	20	10
M 8	35	22	10
M10	35	26	10
M12	35	30	10
M14	35	38	10

183X-75 (XZN)	L (mm)	R (mm)	(g)	(pcs.)
M 4	75	6	34	10
M 5	75	6	34	10
M 6	75	6.2	36	10
M 8	75	7.4	39	10
M10	75	9.8	54	10
M12	75	11.7	57	10
M14	75	13.5	67	10

183X-150 (XZN)	L (mm)	R (mm)	(g)	(pcs.)
M 5	150	6	50	10
M 6	150	6.2	53	10
M 8	150	7.4	64	10
M10	150	9.8	93	10
M12	150	11.7	121	10
M14	150	13.5	151	10

The items with have larger output sizes than 7/16" Input drive. Due to this design the maximum output torque rating is less than standard.

Die mit gekennzeichneten Artikel haben größere Abtriebsgrößen als der 7/16" Antrieb. Aufgrund dieser Konstruktion ist das maximale Abtriebsdrehmoment geringer als der Standardwert.

Les articles marqués d'un ont des tailles de sortie plus importantes que l'entraînement d'entrée 7/16". En raison de cette conception, le couple de sortie maximum est inférieur au couple standard.

NV13134	D ₁ (mm)	D ₂ (mm)	H (mm)	L (mm)	(g)	(pcs.)	Ⓢ
NV13134	24	22	15	45	100	5	*1

*1 C-Ring=C31, Pin/O-Ring=A31/B31 → P268-269

For DIN3126 E11.2 Bits
Für DIN3126 E11.2 Bits
Pour DIN3126 E11.2 Embouts

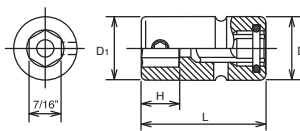
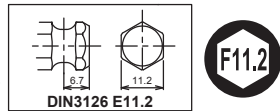

16134-SC

Replacement Screw : M8x6, ● 4mm

NV14134	D ₁ (mm)	D ₂ (mm)	H (mm)	L (mm)	(g)	(pcs.)	Ⓢ
NV14134	24	25	15	55	130	5	*1

*1 C-Ring=C41, Pin/O-Ring=A41/B41 → P268-269

For DIN3126 E11.2 Bits
Für DIN3126 E11.2 Bits
Pour DIN3126 E11.2 Embouts

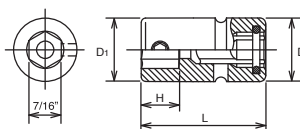
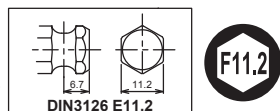

16134-SC

Replacement Screw : M8x6, ● 4mm

Sleeve-Drive Sockets

Sleeve-Drive Steckschlüssel

Douilles, Sleeve Drive

1/2"

NV14400

6-point Sockets
6-kant Steckschlüssel
Douilles 6-pans

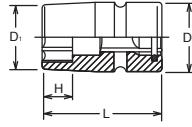

NV14400 (mm)	D ₁ (mm)	D ₂ (mm)	H (mm)	L (mm)	(g)	(pcs.)	
12	19.5	25	9	54	120	10	*1
13	20.7	25	10	54	120	10	*1
14	22	25	10	54	120	10	*1
15	23.2	30	11	54	188	10	*2
16	24.5	30	11	54	189	10	*2
17	25.7	30	12	54	190	10	*2
18	27	30	12	54	190	10	*2
19	28.2	30	12	54	190	10	*2
21	30.7	30	12	54	191	10	*2
22	32	30	12	54	192	10	*2
23	33.2	30	12	54	196	10	*2
24	34.5	30	12	54	200	10	*2

*1 C-Ring=C41, Pin/O-Ring=A41/B41 → P268-269
*2 C-Ring=C42, Pin/O-Ring=A42/B42

NV14145-100 / -150 / -200

Extended Sockets
Schaftsteckschlüssel
Douilles rallongées



NV14145-100 (mm)	D ₁ (mm)	D ₂ (mm)	H (mm)	L (mm)	(g)	(pcs.)	
10	15.5	25	10	100	161	1	*1
12	18	25	12	100	178	1	*1
13	19	25	13	100	175	1	*1
14	21	25	14	100	181	1	*1
15	22	25	15	100	185	1	*1
16	24	25	15	100	193	1	*1
17	25	25	15	100	201	1	*1
18	26	25	15	100	211	1	*1
19	28	25	15	100	221	1	*1

NV14145-150 (mm)	D ₁ (mm)	D ₂ (mm)	H (mm)	L (mm)	(g)	(pcs.)	
10	15.5	25	10	150	200	1	*1
12	18	25	12	150	215	1	*1
13	19	25	13	150	220	1	*1
14	21	25	14	150	225	1	*1
15	22	25	15	150	230	1	*1
16	24	25	15	150	240	1	*1
17	25	25	15	150	250	1	*1
18	26	25	15	150	262	1	*1
19	28	25	15	150	275	1	*1

NV14145-200 (mm)	D ₁ (mm)	D ₂ (mm)	H (mm)	L (mm)	(g)	(pcs.)	
10	15.5	25	10	200	236	1	*1
12	18	25	12	200	250	1	*1
13	19	25	13	200	260	1	*1
14	21	25	14	200	270	1	*1
15	22	25	15	200	275	1	*1
16	24	25	15	200	287	1	*1
17	25	25	15	200	300	1	*1
18	26	25	15	200	310	1	*1
19	28	25	15	200	320	1	*1

*1 C-Ring=C41, Pin/O-Ring=A41/B41 → P268-269

NV14760-P

Extension Bars
Verlängerungen
Rallonges

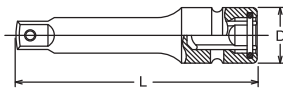

	TYPE	D (mm)	L (mm)	(g)	(pcs.)	
NV14760-75P	Pin	25	75	149	10	*1
NV14760-125P	Pin	25	125	226	5	*1
NV14760-175P	Pin	25	175	308	5	*1
NV14760-250P	Pin	25	250	422	1	*1

*1 C-Ring=C41, Pin/O-Ring=A41/B41 → P268-269

NV14433A-P

Adaptors
Verbindungsstücke
Réducteurs

No Warranty
Keine Garantie
Sans Garantie

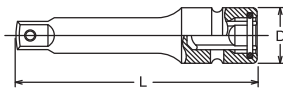

NV14433A	凹 (mm)	凸 (mm)	D (mm)	L (mm)	(g)	(pcs.)	
NV14433A-75P	1/2"	3/8"	25	75	120	10	*1
NV14433A-100P	1/2"	3/8"	25	100	145	10	*1
NV14433A-150P	1/2"	3/8"	25	150	187	5	*1

*1 C-Ring=C41, Pin/O-Ring=A41/B41 → P268-269

⚠ Adapting down from bigger square drive to smaller square drive may lead to excessive torque load and possibly cause breakage. Always stay within safe torque of the smaller square drive.

Die mit ⚠ gekennzeichneten Artikel können bei Überbelastung zu Bruch gehen. Aus Gründen Ihrer eigenen Sicherheit sollten die betreffenden Werkzeuge nie ruckartig, sondern nach und nach belastet werden, um Bruch und damit verbundene mögliche Verletzungen zu vermeiden.

Il est possible d'appliquer aux articles marqués ⚠ des couples de serrage susceptibles d'occasionner leur rupture. Pour votre propre sécurité, veuillez toujours appliquer la charge d'une manière uniforme et progressive. Ceci pour éviter ruptures et accidents.

3/4" Sleeve-Drive Sockets

Sleeve-Drive Steckschlüssel

Douilles, Sleeve Drive

NV16400 (mm)	D ₁ (mm)	D ₂ (mm)	H (mm)	L (mm)	⚖️ (g)	📦 (pcs.)	⚡
17	30	44	12	65	448	5	*1
18	31.3	44	13	65	470	5	*1
19	32.5	44	13	65	455	5	*1
21	35	44	15	65	472	5	*1
22	36.3	44	16	65	471	5	*1
23	37.5	44	16	65	471	5	*1
24	38.8	44	16	65	467	5	*1
26	41.3	44	16	65	477	5	*1
27	42.5	44	16	65	473	5	*1
28	43.8	44	16	68	483	5	*1
29	45	44	18	68	464	5	*1
30	46.3	44	18	68	492	5	*1
32	48.8	44	19	70	514	5	*1
33	50	44	20	70	564	5	*1
34	51.3	44	20	70	588	5	*1
35	52.5	44	20	70	593	5	*1
36	53.8	44	20	70	598	5	*1
38	56.3	44	20	72	670	2	*1
41	60	44	22	72	687	2	*1
46	66.3	44	23	77	906	2	*1
50	69	44	23	77	1116	2	*1

*1 C-Ring=C61, Pin/O-Ring=A61/B61 P268-269

NV16400 6-point Sockets
6-kant Steckschlüssel
Douilles 6-pans

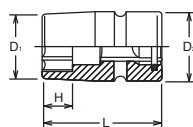

NV16760 Extension Bars
Verlängerungen
Rallonges



	D (mm)	L (mm)	⚖️ (g)	📦 (pcs.)	⚡
NV16760-175	44	175	870	1	*1
NV16760-250	44	250	1160	1	*1
NV16760-330	44	330	1460	1	*1

*1 C-Ring=C61, Pin/O-Ring=A61/B61 P268-269

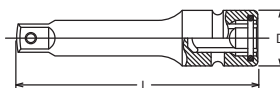

Z-SERIES
HAND
TITANIUM
ACCESSORIES
SCREWDRIVERS
IMPACT
SLEEVE-DRIVE
PROTECTOR
INDUSTRIAL
AUTOMOTIVE
MOTORCYCLE
CONSTRUCTION
SPARE PART